

This drawing and this design and all novel and patentable features separately or collectively disclosed and included therein, are the property of Engineered Flexible Products, Inc., and are not to be copied or to be used directly or indirectly, by anyone whomsoever without the written consent of said company. This drawing is loaned subject to return to said company upon their demand.

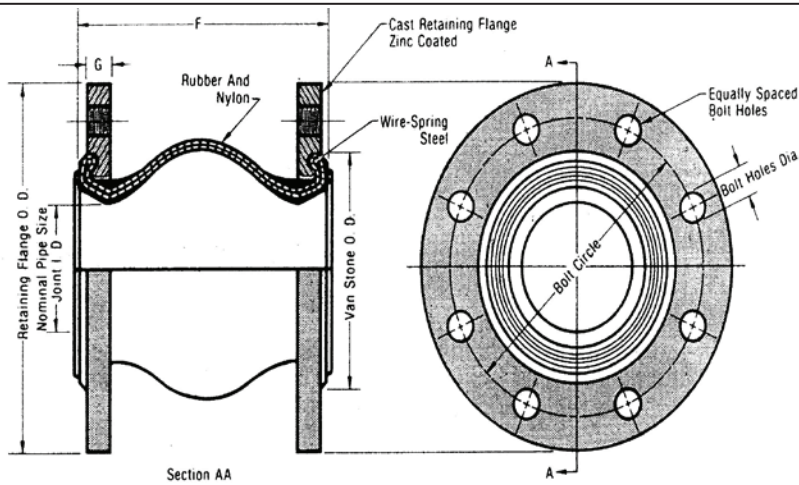

***Maximum Operating Conditions**

Temperature (°F)	Maximum Pressure PSI
	12" & Smaller
170°	225
180°	200
190°	175
210°	150
200°	125
220°	100
230°	75

Contact factory for other elastomers. Not for steam applications.

Data	Item Number	301NP0200	301NP0250	301NP0300	301NP0400	301NP0500
Number Required						
EFP Style Number		301NP0200	301NP0250	301NP0300	301NP0400	301NP0500
Dimensions	Pipe Size-Joint I.D.	2.00"	2.00"	3.00"	4.00"	5.00"
	F-Length of Joint	6.00"	6.00"	6.00"	6.00"	6.00"
	A-Flange Width	0.63"	0.71"	0.71"	0.71"	0.79"
Bolting	Flange/Ring O.D.	6.00"	7.00"	7.50"	9.00"	10.00"
	Bolt Circle	4.75"	5.50"	6.00"	7.50"	8.50"
	Number & Hole Size	4 - 0.75"	4 - 0.75"	4 - 0.75"	8 - 0.75"	8 - 0.88"
Movements	Axial Compression	0.500"	0.500"	0.500"	0.750"	0.750"
	Axial Extension	0.375"	0.375"	0.375"	0.500"	0.500"
	Lateral Deflection	0.500"	0.500"	0.500"	0.500"	0.500"
	Angular Movement	20°	17°	14°	14°	11°
Physical	Pressure Rating ⁽¹⁾	225 PSI	225 PSI	225 PSI	225 PSI	225 PSI
	Vacuum Rating ⁽¹⁾	26 In/Hg	26 In/Hg	26 In/Hg	26 In/Hg	26 In/Hg
	Temperature Rating	212 °F	212 °F	212 °F	212 °F	212 °F
	FSA Pressure Series	C	C	C	C	C
	FSA Material Class	Standard	Standard	Standard	Standard	Standard
Approx. Weights	Expansion Joint	12.3 LBS	12.3 LBS	14.0 LBS	18.3 LBS	22.8 LBS
	Control Unit Set(2 rods)	-	-	-	-	-
	Packing Crates	-	-	-	-	-
	Total Approx. Wght Ea.	12.3 LBS	12.3 LBS	14.0 LBS	18.3 LBS	22.8 LBS
Materials	Tube Elastomer	NITRILE	NITRILE	NITRILE	NITRILE	NITRILE
	Cover Elastomer ^(®)	NEOPRENE	NEOPRENE	NEOPRENE	NEOPRENE	NEOPRENE
	Body Fabric	NYLON	NYLON	NYLON	NYLON	NYLON
	Body Reinforcing	FABRIC	FABRIC	FABRIC	FABRIC	FABRIC
	Control Units	-	-	-	-	-

WARNING: Control units must be used to protect this part from excessive movement if piping is not properly anchored. Expansion joints may operate in pipelines or equipment carrying fluids and/or gases at elevated temperature and pressures. Normal precautions should be taken to make sure these parts are installed correctly and inspected regularly. Precautions should be taken to protect personnel in the event of leakage or splash.



5331 Quam Ave., N.E.
St. Michael, MN 55376 - USA
PH: 763-201-2151
FAX: 763-201-2134

SCALE: NONE

PRINT CERTIFICATION: Certified correct as of 4/15/14 by

R. Vance, (Pres.) Subscribed & sworn to before me, on this 15th day of April, 2014
By: _____ (Notary Public)

DWG NO: 9	PROP/INQ/ORD. NO:	REMARKS:
FORM NO: SINGLE SPHERE	CUSTOMER NAME:	⁽¹⁾ PRESSURE RATING IS BASED ON 170° F. MOVEMENTS ARE NON-CONCURRENT.
APPVD BY: RV CHECKED BY: RV	PROJECT NAME:	
PROD. DESC:	CONTRACTOR:	
THE ABOVE EXPANSION JOINTS AND RELATED HARDWARE, MEET OR EXCEED THE PHYSICAL, MECHANICAL OR MATERIAL SPECIFICATIONS OF THE RUBBER EXPANSION JOINT DIV., FLUID SEALING ASSOCIATION. FOR ADDITIONAL INFORMATION, SEE THE ASSOCIATION, "TECHNICAL HANDBOOK, FIFTH EDITION", CHAPTER II, PARAGRAPH A.1. AND TABLES II, III, AND IV.		HAVE CONTROL UNITS BEEN SPECIFIED/ORDERED FOR THIS INSTALLATION: NO